

Miele

Operating and installation instructions





Oven H 4710 B, H 4810 B

To avoid the risk of accidents or damage to the appliance it is **essential** to read these instructions before it is installed and used for the first time.

en - GB

M.-Nr. 09 000 750

Contents

Warning and Safety instructions	5
Caring for the environment	10
Guide to the appliance	11
H 4710 B, H 4810 B	11
Features	12
Oven controls	12
Safety features	12
Cooling fan	12
Vented oven door	12
PerfectClean treated surfaces	12
Catalytic enamelled surfaces	12
Energy efficiency rating according to EN 50304	12
Accessories	13
Baking tray, universal tray and rack with non-tip notches	13
Anti-splash insert	13
Handle	14
Controls	15
Function selector	15
Temperature selector	15
Temperature indicator light 	15
Oven functions	16
Before using for the first time	18
To set the time of day for the first time	18
Cleaning and heating up for the first time	18
Clock/Timer	20
Sensor controls	20
Operation	20
The time shown in the display	21
Changing the time of day	21
Changing the audible tone	22
Using the minute minder  function	22
Setting the minute minder	23
Altering the time set for the minute minder	23
Cancelling the time set for the minute minder	23
Operation	24
Using the oven	24
Pre-heating	24

Switching on and off automatically	25
Entering a duration	25
Entering a duration and a finish time	26
At the end of the duration	27
Checking and changing an entered duration.	27
Deleting a duration	27
Baking tips	28
Bakeware	28
Baking parchment	28
Universal tray	28
Rectangular tins	28
Notes about the charts	29
Temperature, baking duration	29
Shelf level	29
Frozen food	29
Baking chart	30
Roasting tips	34
Useful tips	35
Browning	35
Standing time	35
Roasting poultry	35
Frozen meat	35
Roasting chart	36
Notes on Slow cooking	37
Proceed as follows:	37
Cooking duration/Core temperatures	38
Grilling tips	39
Preparing food for grilling	41
Grilling	41
Useful tips	41
Grilling chart.	42
Defrost	43
Cooking ready meals.	44
Cleaning and care	45
Appliance front	45
Accessories	46
Universal tray, baking tray , anti-splash insert	46

Contents

Rack, runners	46
Oven interior	46
Seal and inside of the oven door	46
PerfectClean	47
Catalytic enamel surfaces	49
To remove the oven door	50
To dismantle the oven door	51
To refit the door	53
To remove the runners	54
To remove the catalytic enamelled back panel, side panels and roof liner	54
Back panel	54
Roof liner (if fitted)	55
Side panels (if fitted)	55
Problem solving guide	56
After Sales / Guarantee	58
Optional accessories	59
Electrical connection	61
Building-in diagrams	62
Appliance and niche dimensions	62
Front dimensions	63
Installing the oven	64

Warning and Safety instructions

This appliance conforms to current safety requirements. Inappropriate use can, however, lead to personal injury and damage to property.

To avoid the risk of accidents and damage to the appliance, please read these instructions carefully before using it for the first time. They contain important notes on installation, safety, use and maintenance.

Keep these instructions in a safe place and ensure that new users are familiar with the content. Pass them on to any future owner.

Correct application

► This oven is not designed for commercial use. It is intended for use in domestic households and for use in similar working and residential environments such as:

- Shops
- Offices and showrooms

and by residents in establishments such as:

- Hostels and guest houses

► It is intended for domestic use only to cook food, and in particular to bake, roast, grill, defrost and dry food.

Any other use is not supported by the manufacturer and could be dangerous. Miele cannot be held liable for damage resulting from incorrect or improper use or operation of the appliance.

► This appliance is not intended for use by persons (including children) with reduced physical, sensory or mental capabilities, or lack of experience and knowledge, unless they are supervised whilst using it, or have been shown how to use it correctly by a person responsible for their safety.

Warning and Safety instructions

Safety with children

▶ This appliance is not a toy! To prevent the risk of injury or damage, do not let children play with the appliance or its controls.

▶ Older children may only use the oven when its operation has been clearly explained to them and they are able to use it safely, recognising the dangers of misuse.

▶ Great care should be taken to ensure that children do not touch the appliance when it is being used. Children's skin is far more sensitive to high temperatures than that of adults. External parts of the oven such as the door glass, control panel and the vent become quite hot.

Technical safety

▶ Installation, maintenance and repairs may only be carried out by a suitably qualified and competent person in strict accordance with current national and local safety regulations. Repairs and other work by unqualified persons could be dangerous. The manufacturer cannot be held liable for unauthorised work.

▶ Before installation, check the appliance for visible signs of damage. Do not install and use a damaged appliance. A damaged appliance could be dangerous.

▶ The electrical safety of this appliance can only be guaranteed when continuity is complete between it and an effective earthing system. It is most important that this basic safety requirement is present and tested regularly, and where there is any doubt the household wiring system should be inspected by a qualified electrician. The manufacturer cannot be held liable for the consequences of an inadequate earthing system (e.g. electric shock).

Warning and Safety instructions

▶ Before connecting the appliance, make sure that the connection data on the data plate (voltage and connected load) match the mains electricity supply.

This data must correspond in order to avoid the risk of damage to the appliance. Consult a competent person if in doubt.

▶ Do not connect the appliance to the mains electricity supply by a multi-socket unit or an extension lead. These do not guarantee the required safety of the appliance (e.g. danger of overheating).

▶ For safety reasons, this appliance may only be used when it has been built in.

▶ Never open the housing of the appliance.

Tampering with electrical connections or components and mechanical parts is highly dangerous to the user and can cause operational faults.

▶ While the appliance is under guarantee, repairs should only be undertaken by a service technician authorised by the manufacturer. Otherwise the guarantee will be invalidated.

▶ During installation, maintenance and repair work, the appliance must be disconnected from the mains electricity supply. It is only completely isolated from the electricity supply when:

- the mains fuse is disconnected,
- the screw-out fuse is removed (in countries where this is applicable),
- it is switched off at the isolator.

Ensure that current is not supplied to the appliance until after maintenance or repair work has been carried out.

▶ Faulty components must only be replaced by genuine Miele original spare parts. The manufacturer can only guarantee the safety of the appliance when Miele replacement parts are used.

▶ If the supply cord is damaged, it must be replaced by a Miele approved service technician to avoid a hazard.

▶ This appliance may only be used in mobile installations such as ships if a risk assessment of the installation has been carried out by a suitably qualified engineer.

▶ In countries where there are areas which may be subject to infestation by cockroaches or other vermin, pay particular attention to keeping the appliance and its surroundings in a clean condition at all times. Any damage which may be caused by cockroaches or other vermin will not be covered by the guarantee.



Warning and Safety instructions





Correct use

Caution. Danger of burning.
High temperatures are produced by the oven.

► Use oven gloves when placing food in the oven, turning or removing it and when adjusting oven shelves etc. in a hot oven. Be very careful that you do not burn yourself on the top heating / grill element.

► Never leave the appliance unattended when cooking with oil or fats, as these are a fire hazard if allowed to overheat.

► Do not exceed the recommended grilling times when using the "Full grill , "Economy grill " and "Fan grill " functions. Excessively long grilling times can lead to food drying out and burning, or could even cause it to catch fire.

► Do not use the "Full grill , "Economy grill " or "Fan grill " to finish baking part-cooked rolls or bread or to dry flowers or herbs. Fire hazard. Use "Fan plus " or "Conventional heat " instead.





► If using alcohol in your recipes, high temperatures can cause the alcohol to vaporise and even to ignite on the hot heating elements.

Alcohol should be burnt off before the dish is placed in the oven to avoid this danger.

► Cover any food which is left in the oven to be kept hot. Any moisture in the food could lead to corrosion damage in the oven. This also prevents the food from drying out.

► If you wish to complete a cooking process using the residual heat in the oven, leave the function selector at the position set and turn the temperature selector to the lowest setting. Do not switch the appliance off until the food has been removed. Increased moisture in the oven could cause condensation to form which could lead to

- corrosion in the oven compartment.
- damage to the control panel, worktop and surrounding kitchen furniture.

► Do not line the floor of the oven with aluminium foil when using "Conventional heat " / "Bottom heat " / "Intensive bake " / "Rapid heat-up ". This would cause a build-up of heat which could cause damage to the floor of the oven.

For this reason do not place a dish, tin or baking tray directly on the oven floor.

Warning and Safety instructions

If using a tray made by a different manufacturer, make sure that there is a gap of at least 6 cm between the bottom of the tray and the floor of the oven.

▶ Never add cold water to food on a hot universal tray or baking tray or directly onto food in a hot oven. The steam created could cause serious burns or scalding and the sudden change in temperature can damage the enamel.

▶ Always ensure that food is suitably cooked or reheated.

Some foods may contain micro-organisms which are only destroyed by thorough cooking at temperatures over 70 °C for a minimum of 10 minutes. Therefore when cooking or reheating foods, e.g. poultry, it is particularly important that food is fully cooked through. If in doubt select a longer cooking or reheating time. It is important that the heat is allowed to spread evenly throughout the food being cooked. This can be achieved by stirring and/or turning the food during cooking.

▶ If using plastic containers for cooking, they must be declared by the manufacturer as being suitable for use in an oven. Other types of plastic containers melt at high temperatures, and could damage the oven.

▶ Do not heat up unopened tins or jars of food in the oven. Pressure can build up and they may explode, resulting in injury or damage.

▶ Do not push pots and pans around on the oven floor, as this could damage the surface.

▶ Do not lean or sit on an open oven door, or place heavy items on it. Make sure that nothing gets trapped between the door and the oven compartment. This could damage the oven. The oven door can support a maximum load of 15 kg.

▶ Do not use the appliance to heat up the room. Due to the high temperatures radiated, objects near the appliance could catch fire.

Accessories

▶ Only use genuine Miele original spare parts and accessories with this appliance. Using spare parts or accessories from other manufacturers will invalidate the guarantee, and Miele cannot accept liability.

The manufacturer cannot be held liable for damage caused by non-compliance with these Warning and Safety instructions.

Caring for the environment

Disposal of the packing material

The transport and protective packing has been selected from materials which are environmentally friendly for disposal, and should be recycled.

Ensure that any plastic wrappings, bags, etc. are disposed of safely and kept out of the reach of babies and young children. Danger of suffocation.

Disposing of your old appliance

Electrical and electronic appliances often contain materials which, if handled or disposed of incorrectly, could be potentially hazardous to human health and to the environment. They are, however, essential for the correct functioning of your appliance. Please do not dispose of it with your household waste.

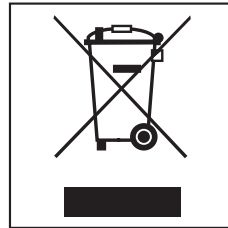

Please dispose of it at your local community waste collection / recycling centre or contact your dealer for advice. Ensure that it presents no danger to children while being stored for disposal.

H 4710 B, H 4810 B

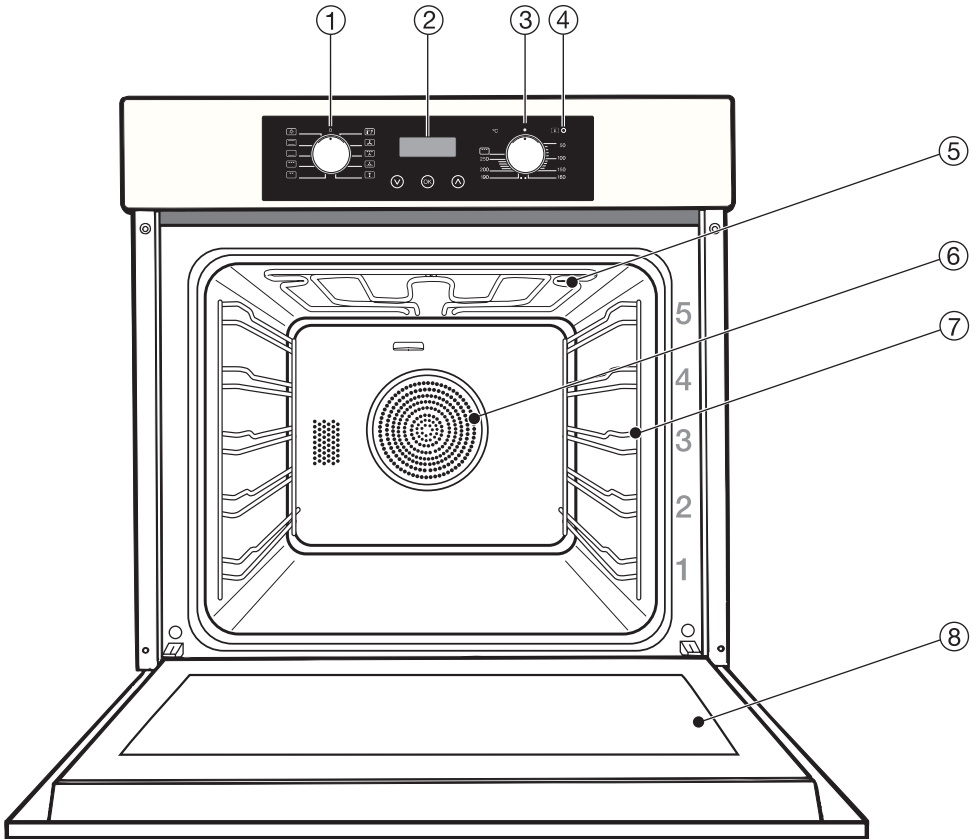

- ① Function selector, retractable when it is at "0"
- ② Clock/timer with sensors ▼, OK, ▲
- ④ Temperature selector, retractable when it is at "0"
- ④ Temperature indicator light 
- ⑤ Heating element for top heat and grilling
- ⑥ Catalytic enamelled back panel with air inlet for the fan
- ⑦ Side runners with five shelf levels
- ⑧ Door

Features

Oven controls

In addition to operating the various cooking programmes to bake, roast and grill, the controls on ovens with a clock/timer also offer the following:

- a time of day display,
- a minute minder,
- a timer to automatically switch cooking programmes on and off,
- settings that can be customised.

Safety features

Cooling fan

A cooling fan will come on automatically when a cooking programme is started. The cooling fan mixes hot air from the oven cavity with cool room air before venting it out into the kitchen through vents located between the appliance door and the control panel.

The cooling fan will continue to run after the oven has been switched off to prevent any humidity building up in the oven, on the control panel or on the oven housing unit.

When the temperature in the oven has fallen sufficiently, the cooling fan will switch off automatically.

Vented oven door

The oven door is an open system and one of the door panes has a heat-reflecting coating. During operation, cool air is passed through the oven door to keep the outer pane cool.

If necessary, the oven door can be dismantled for cleaning.

See "Cleaning and care" for more information.

PerfectClean treated surfaces

The following surfaces are all treated with a special PerfectClean finish:

- Oven interior
- Universal tray
- Baking tray (if applicable)
- The anti-splash insert (if applicable).

PerfectClean surfaces have very good anti-stick properties and are much easier to keep clean than conventional enamel, if cleaned regularly.

See "Cleaning and care" for more information.

Catalytic enamelled surfaces

The back panel is coated with dark grey catalytic enamel. Soiling from oil and fat is burnt off this enamel when very high temperatures are used in the oven.

See "Cleaning and care" for more information.

Energy efficiency rating according to EN 50304

This appliance is rated energy efficiency class **A** in accordance with EN 50304.

Tests were carried out using Fan plus  with any FlexiClip telescopic runners removed.

Accessories

Depending on model, your appliance will be supplied with some of the following accessories.

These and other accessories are also available to order from the Miele Spare Parts Department, your Dealer or via the internet at www.miele-shop.com.

Baking tray, universal tray and rack with non-tip notches

(depending on model)

Baking tray:

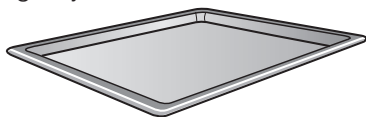

Universal tray:

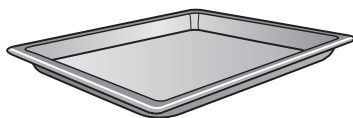

Rack:

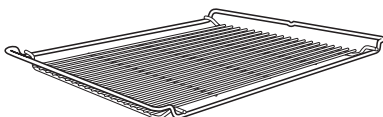

The baking tray, universal tray and rack are inserted into the oven between the two rails of a shelf runner.

The short sides of the trays and rack have a safety notch in the middle. This notch prevents the tray or rack from sliding completely out of the oven when it is partially pulled out.

To remove the trays or rack, they need to be lifted out.

Always place the rack in the oven with the slats facing downwards, as illustrated.



If you are using a tray with the rack on top, insert the tray between the rails of a shelf runner and the rack will sit on top of it.

Anti-splash insert

(depending on model)

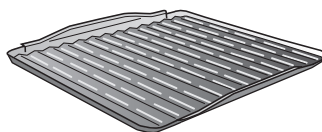

The anti-splash insert should be placed in the universal tray when grilling or roasting.

The juices from the food being cooked collect under the anti-splash insert. This prevents them from spitting and making the oven dirty. The juices can then be used for making gravy and sauces.

Features

Handle

(depending on model)

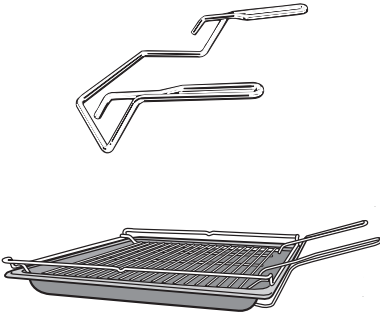

The handle makes it easier to take the universal tray, baking tray and rack out of the oven, or to put them into it. The two prongs at the top go inside the tray or above the rack, and the U-shaped supports underneath.

Function selector

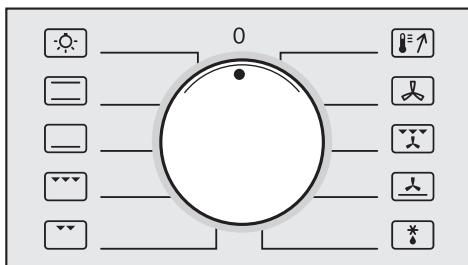

The left-hand control is used to select the function.

The function selector can be turned clockwise or anti-clockwise.

It can only be retracted when it is at "0".

 Rapid heat-up

 Fan plus

 Fan grill

 Intensive bake

 Defrost

 Conventional heat

 Bottom heat

 Full grill

 Economy grill

 Lighting:

For switching on the oven light independently. This can be useful when cleaning the oven.

Temperature selector

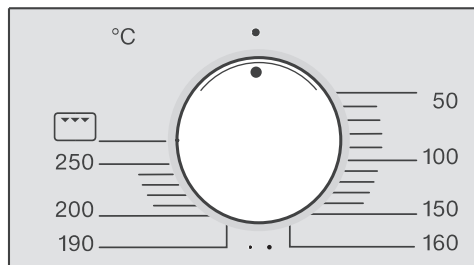

The right-hand control is used to select the temperature.

The temperature selector must only be turned in a clockwise direction as far as it will go, and then back again.

It can only be retracted when it is at "0".

Temperature indicator light

The temperature indicator light  is next to the temperature selector.

The indicator light is always on when the oven heating is on.

When the set temperature is reached,

- the oven heating switches off.
- the temperature indicator light goes out.

As soon as the temperature falls below the set temperature, the oven heating and the temperature indicator light will switch on again.





Oven functions









Your oven has a range of oven functions for preparing a wide variety of recipes.

Heat is created in the oven by means of different elements and components:

- Ⓐ Top heat/grill element (under the roof of the oven)
- Ⓑ Bottom heating element (under the floor of the oven)
- Ⓒ Ring heating element (behind the intake vent for the fan)
- Ⓓ Fan (behind the intake vent for the fan)

These elements and components are combined in various ways, depending on the oven function selected. See the letters given in brackets for each function.

Oven function	Notes
 Conventional heat [Ⓐ + Ⓑ]	<ul style="list-style-type: none">– For baking traditional recipes, e.g. fruit cake, casseroles.– Also ideal for soufflés.– If using an older recipe or cookbook, set the oven temperature for Conventional heat 10°C lower than that recommended.– The cooking duration does not need to be changed.
 Bottom heat [Ⓑ]	<ul style="list-style-type: none">– Use this setting towards the end of baking to brown the base of a cake, quiche or pizza.
 Full grill [Ⓐ]	<ul style="list-style-type: none">– The whole grill element is switched on and glows red in order to create the heat required.– For grilling larger quantities of thin cuts (e.g. steaks).– For browning food in larger dishes.
 Economy grill [Ⓐ]	<ul style="list-style-type: none">– The inner part of the grill element is switched on and glows red in order to create the heat required.– For grilling smaller quantities of thin cuts (e.g. steaks).– For browning food in smaller dishes.

Oven function	Notes
 Rapid heat-up [(A) + (C) + (D)]	<ul style="list-style-type: none"> – For pre-heating the oven compartment. The oven function required must then be selected.
 Fan plus [(C) + (D)]	<ul style="list-style-type: none"> – For baking and roasting. – You can bake and roast on different levels at the same time. – Lower temperatures can be used than with Conventional heat  as the Fan plus system distributes the heated air around the food.
 Fan grill [(A) + (D)]	<ul style="list-style-type: none"> – For grilling larger items, e.g. rolled meat, poultry. – The hot air from the grill is distributed over the food by the fan. This enables a lower temperature to be selected than when using Full grill /Economy grill .
 Intensive bake [(B) + (C) + (D)]	<ul style="list-style-type: none"> – For cooking dishes which require a moist topping and a crisp base such as pizza and quiche lorraine. – Intensive bake is not suitable for baking thin biscuits etc. or for roasting as the juices will become too dark.
 Defrost [(D)]	<ul style="list-style-type: none"> – For the gentle defrosting of frozen food.

Before using for the first time

Before the oven can be used, you will need to

- release the controls by pressing them in, if they are pushed in when the oven is delivered.
- set the time of day (on ovens with a clock/timer).

To set the time of day for the first time

The clock/timer has a 24 hour display.



After connecting the appliance and switching it on, a dot ● will light up and 00 00 will flash in the display.

- Press the OK sensor.

00 00 will light up in the display and the dot ● will flash.

- Enter the time of day using the ▼ or ▲ sensors whilst the dot ● is flashing in the display.

- Press the OK sensor.

The time of day is saved and the dot ● now lights up continuously.

The time then counts in minutes.

Cleaning and heating up for the first time

Before use, please remove

- any stickers from the oven and from any accessories.
- any protective foil from the oven front.

See "Cleaning and care" for more information.

Before using the oven for the first time

- take **all accessories** out of the oven and wash them.
- then **heat the oven up once with nothing in it**. New ovens have a slight smell on first use and this will dissipate the smells before you use it to cook food.
- Wipe the oven interior out with a damp cloth to remove any dust or bits of packaging that may have accumulated in the oven cavity during storage and unpacking.
- Press and release the function selector and the temperature selector.
- Select Fan plus  with the function selector.
- Set the highest temperature (250 °C) with the temperature selector.

Before using for the first time

The oven will start heating up as soon as this entry has been accepted.

- Heat the empty oven for at least an hour.

Please ensure the kitchen is well ventilated during this operation. Close doors to other rooms to prevent the smell spreading throughout the house.

The oven can be set to switch off automatically at the end of the heating up process. See "Operation – Entering a duration.

- Leave the appliance to cool down to room temperature.
- Then wipe the oven interior out with a solution of hot water and a mild detergent, and dry it thoroughly with a soft clean cloth.

Leave the oven door open until the oven interior is completely dry.

Clock/Timer

The clock/timer (depending on model) can:

- display the time of day.
- be used as a minute minder.
- switch the oven off, or on and off, automatically.

Sensor controls

The oven has sensors which react to touch.





A keypad tone sounds each time a sensor is touched.

Operation





The clock/timer is operated using the **OK**, **^** and **v** sensors together with the **display**.

Sensor	Use
OK	<ul style="list-style-type: none">- To select the minute minder Δ function- To select the duration clock function- To select the finish time clock function- To save an entry
v and ^ at the same time	<ul style="list-style-type: none">- To select the time of day \bullet function- To delete a time
^	<ul style="list-style-type: none">- To increase a time- To change the audible tone
v	<ul style="list-style-type: none">- To reduce a time- To call up the Audible tone option function- To change the audible tone

When you select a function, its symbol will flash in the display, e.g. , ,  or .

You can only enter a time/duration while the symbol is flashing (15 seconds approx.).

If you fail to make an entry during these 15 seconds, you will have to call up the symbol in the display again using the OK sensor.





Each press of the  or  sensor alters the time in one minute increments. Holding one of these sensors in will speed up the process.

To save your entry, touch the OK sensor or wait for approx. 15 seconds.

After this time, your entry will be saved automatically and the symbol will light up.



The time shown in the display





If a minute minder time has been entered, this will generally take precedence in the display.

If a duration  and/or finish time  have been entered, the time of day will take precedence in the display. The  and  symbols indicate which of these has been entered. The duration and/or finish time can be called up by touching the OK sensor.

Changing the time of day

The clock/timer has a 24 hour display.

The time of day can only be altered if no cooking time (duration ) and/or finish time () has been entered.

- Touch the  and  sensors at the same time.
- Enter the time of day using the  or  sensors whilst the dot  is flashing in the display.
- Touch the OK sensor.

The entry is saved and the dot  now lights up continuously.

If there is a power cut, the time of day will need to be re-entered.

Clock/Timer

Changing the audible tone

There is a choice of several different tones.

- Touch the **▼** sensor until **5** appears in the display together with a number, e.g.:



The audible tone assigned to this permutation will sound at the same time.

Each time the **▼** or **▲** sensor is touched, a different tone sounds.

5 0 to **5 30** represent the choice available.

- Touch the **▼** or **▲** sensor until you reach the audible tone of your choice.
- Touch the OK sensor to save your choice.

Alternatively, wait for approx. 15 seconds: the audible tone that sounded the last time a sensor was touched will be automatically saved after this time lapse.

If there is a power cut, the audible tone will automatically revert to the factory default setting and will need to be reset.

Using the minute minder function

The minute minder can be used to time any activity in the kitchen, e.g. boiling eggs.

You can set the minute minder at the same time as another programmed cooking time, e.g. as a reminder to baste your roast or add seasoning etc.

A minute minder time can be entered between 1 minute and 23 hours 59 minutes.

Setting the minute minder

- Touch the OK sensor repeatedly until the \triangle symbol starts to flash in the display.



0:00 will appear in the display.

- Enter the time required for the minute minder using the ∇ or \blacktriangle sensor whilst the bell symbol \triangle is flashing.
- Touch the OK sensor.

This saves your entry.

The \triangle symbol continues to be visible as a reminder that a minute minder time has been entered, and the minute minder time then counts down in the display.

The time counts down in seconds for the last minute.

At the end of the time set for the minute minder

- the bell symbol \triangle will start flashing,
- an audible tone will sound for approx. 7 minutes.
- Touch the OK sensor.

The tone will stop and the symbol in the display will go out.

Altering the time set for the minute minder

- Touch the OK sensor repeatedly until the \triangle symbol starts to flash in the display.
- Whilst the \triangle symbol is flashing, enter the time required for the minute minder using the ∇ or \blacktriangle sensors.

Cancelling the time set for the minute minder

- Touch the OK sensor repeatedly until the \triangle symbol starts to flash in the display.
- Whilst the \triangle symbol is flashing, touch the ∇ and \blacktriangle sensors at the same time.

The minute minder time is now deleted and the time of day reappears in the display.

Operation

Using the oven

- Place the food in the oven.
- Use the function selector to set the function.

The oven interior light comes on.

- Set the temperature with the temperature selector.

The oven heating and the cooling fan will switch on.

- Take the food out of the oven when it is ready.
Turn the function selector and the temperature selector back to the "0" position.



The cooling fan will continue to run to prevent any humidity building up in the oven, on the control panel or on the oven housing unit.

When the temperature in the oven has fallen sufficiently, the cooling fan will switch off automatically.

Pre-heating

Most dishes can be placed in a cold oven. They will then make use of the heat produced during the heating-up phase.

It is only necessary to pre-heat the oven in a few instances:

	<ul style="list-style-type: none">– Pre-heating may be necessary for foods which cook in less than 20 minutes and for foods such as puff pastries and yeast mixtures where instant heat is required to make them rise quickly.– for roasting beef/fillet.
	<ul style="list-style-type: none">– It is usually necessary to pre-heat the oven with Conventional heat.

Do not use Rapid heat-up  to pre-heat the oven when baking pizzas or biscuits and small cakes. They will brown too quickly.

To pre-heat the oven:



- Select Rapid heat-up .
- Set a temperature.

The oven will start to heat up.

- When the temperature indicator light  goes out for the first time, set the oven function you require for continued cooking or baking, and place the food in the oven.

Switching on and off automatically

You can programme the oven to switch off automatically or on and off automatically.

For **Automatic switch-off**, you need to enter a duration  or a duration  and finish time .

The maximum duration which can be set is 10 hours.

We recommend using automatic switching on and off when roasting. However, do not delay the start for too long when baking as the cake mixture or dough will dry out, and the raising agents will lose their effectiveness.

Entering a duration

You can programme the oven to switch off automatically by entering a cooking duration.

- Place the food in the oven.
- Select the required function and set the temperature.
- Touch the OK sensor repeatedly until the  symbol starts to flash in the display.



0:00 will appear in the display.

- Enter the duration using the  sensor whilst the  is flashing.

Once the duration entered has been accepted the display will revert to showing the time of day. The  symbol continues to be visible as a reminder that a duration has been entered.

Operation

Entering a duration and a finish time

You can programme the oven to switch on and off automatically by entering a duration and a finish time.

For example:

The time now is 10:45; you want a dish with a cooking duration of 90 minutes to be ready at 13:30.

- Place the food in the oven.
- Select the required function and set the temperature.



The oven heating, lighting and cooling fan will switch on.

First **enter the cooking duration**:

- Touch the OK sensor repeatedly until the  symbol starts to flash in the display.

0:00 will appear in the display.



- Whilst the  is flashing, enter the duration in hours:minutes (1:30) using the  sensor.

Now **enter the finish time**:



- Touch the OK sensor.



The following appears in the display:



- 12:15"
(time of day plus duration:
10:45 + 1:30 = 12:15).
- The  symbol will flash.



- Whilst the  is flashing, set the time you want the programme to finish at (13:30) with the  sensor.

The oven heating, lighting and cooling fan will switch off.

- Touch the OK sensor.

Once the duration entered has been accepted, the display will revert to showing the time of day. The  and  symbols indicate which of these has been entered.

If a minute minder time has also been entered, this will take precedence in the display.

As soon as the start time (13:30 - 1:30 = 12:00) is reached, the oven heating, lighting and cooling fan will switch on.

At the end of the duration

- the oven heating switches off automatically.
 - the cooling fan will continue to run for a while.
 - an audible tone will sound for approx. 7 minutes.
 - the  symbol will flash.
- Touch the OK sensor.

The tone will stop and the symbol in the display will go out.

Important: please note that touching the OK sensor will cause the oven heating to come on again. Switch the oven off if you no longer need it.





Checking and changing an entered duration

- Touch the OK sensor repeatedly until the  symbol starts to flash in the display.

The remaining duration shows in the display.

- The duration can be changed whilst the  symbol is flashing.

Deleting a duration

- Touch the OK sensor repeatedly until the  symbol starts to flash in the display.
- Whilst the  symbol is flashing, touch the  and  sensors at the same time.

The duration is now deleted and the time of day reappears in the display.

The oven will start to heat up as soon as the programmed cooking duration has been deleted. Switch the oven off if you no longer need it.

Baking tips

Refer to the baking charts for suggestions of temperatures, shelf levels and cooking durations. These take into account a range of different baking tins, quantities and cooking traditions.

Handling and preparing food correctly is essential for maintaining good health.

Only bake cakes, pizza, chips etc until they are golden. Do not overcook them.

Bakeware

Please take into account the material of your bakeware in your choice of oven function:

Fan plus , **Intensive bake** 

Any heat-resistant material can be used.

Conventional heat 

Dark metal, enamel or aluminium baking tins with a matt finish, as well as heat-resistant glass and ceramic dishes can be used.

Bright, shiny metal tins result in uneven or poor browning and in some cases cakes might not cook properly.

Baking parchment

Because of their PerfectClean anti-stick surface **the baking tray and the universal tray** do not need to be greased or lined with baking parchment for baking.

Baked goods are easily removed when done.

Baking parchment is only necessary when baking:

- Anything with a **high salt content** (e. g. pretzels, bread sticks), because sodium can damage the PerfectClean surface.
- Meringues or biscuits with a **high egg-white content**, because they are more likely to stick.

Universal tray

When baking cakes with **fresh fruit toppings** and **deep sponge cakes** place the tin in the universal tray to catch any spillages and keep the oven cleaner.

Rectangular tins

Place cakes in loaf tins and rectangular tins with the longer side across the width of the oven for optimum heat distribution and even results.

Notes about the charts



Temperature, baking duration

To achieve even results without over-browning the food,

- always select the **lowest temperature** given in the chart. Do not set a temperature higher than that recommended. Increasing the temperature may reduce the cooking time, but will lead to uneven browning, and unsatisfactory cooking results.
- Check if the food is cooked at the end of the **shortest time quoted**. To check if a cake is ready, insert a wooden skewer into the centre. It is ready if the skewer comes out clean, without dough or crumbs sticking to it.

Shelf level

The shelf levels are counted from the bottom of the oven upwards (1 = lowest, 5 = highest).

	Number of trays	Shelf level
	1	2
	2	1 and 3
	3	1, 3 and 5 *
	1	1 or 2
	1	1 or 2

- * When baking moist cakes, bread etc do not use more than two baking tins at the same time.

The universal tray should be used beneath the baking tray when using two or more levels at the same time.

Frozen food

When baking frozen products such as **cakes, pizza and baguettes**, use the lowest temperature quoted on the manufacturer's packaging. Bake on a layer of baking parchment placed on the rack. Cooking large frozen items on the baking tray or the universal tray can cause the metal to distort. This distortion would increase with subsequent use.

Small items of frozen food such as **oven chips or potato croquettes** can be cooked on the universal tray. Place them on baking parchment and select the lowest temperature quoted on the manufacturer's packaging. Turn several times during cooking.



Baking chart

Cakes / biscuits	Fan plus 		
	Temperature in °C	Shelf level	Duration ¹⁾ in min.
Creamed mixture			
Sponge cake	150–170	2	60–70
Ring cake	150–170	2	65–80
Muffins (1 [2] tray(s))	150–170	2 [1+3]⁴⁾	30–50
Foam cake (tray)	150–170	2	25–40
Marble cake (tin)	150–170	2	60–80
Fresh fruit cake, with filling (tray)	150–170	2	45–50
Fresh fruit cake (tray)	150–170	2	35–55
Fresh fruit cake (tin)	150–170	2	55–65
Flan base ²⁾	150–170	2	25–35
Small cakes/biscuits ²⁾ (1 tray)	150–170	2	20–25
Small cakes/biscuits ²⁾ (2 [3] trays)	140–160	1+3 [+5]⁴⁾	20–25
Rubbed in mixture			
Tart / flan base	150–170	2	20–25
Streusel cake	150–170	2	45–55
Small cakes/biscuits ²⁾ (1 tray)	150–170	2	15–25
Small cakes/biscuits ²⁾ (2 [3] trays)	140–160	1+3 [+5]⁴⁾	15–25
Cheese cake	150–170	2	70–95
Apple pie	160–180	2	50–70
Apricot tart with topping	150–170	2	55–75
Swiss apple pie ³⁾	190–210	2	30–45

The data for the recommended function is printed in bold.

In general, if a range of temperatures/times is given, it is best to select a lower temperature and to check the food after the shortest time.

Baking chart

Conventional heat 			Intensive bake 		
Temperature in °C	Shelf level	Duration ¹⁾ in min.	Temperature in °C	Shelf level	Duration ¹⁾ in min.
150–170	2	60–70	–	–	–
150–170	2	65–80	–	–	–
160–180	2	25–45	–	–	–
170–190	2	25–40	–	–	–
150–170	2	60–80	–	–	–
170–190	2	45–50	–	–	–
170–190	1	35–55	–	–	–
160–180	2	55–65	–	–	–
170–190	2	20–25	–	–	–
160–180	3	15–25 ³⁾	–	–	–
–	–	–	–	–	–
170–190	2	15–20	–	–	–
170–190	2	45–55	–	–	–
160–180	3	15–25	–	–	–
–	–	–	–	–	–
160–180	2	85–95	150–170	2	75–90
170–190	1	45–65	160–180	1	50–70
170–190	2	55–75	150–170	2	50–60
220–240	1	35–50	190–210	1	25–40

- 1) Unless otherwise stated, the times given are for an oven which has not been pre-heated. With a pre-heated oven shorten times by up to 10 minutes.
- 2) Do not use Rapid heat-up  during the heating-up phase.
- 3) Pre-heat the oven.
- 4) Take baking trays out of the oven early if the food is sufficiently browned before the specified time has elapsed.



Baking chart

Cakes / biscuits	Fan plus 		
	Temperature in °C	Shelf level	Duration ¹⁾ in min.
Sponge mix²⁾			
Sponge cake (2 eggs) ²⁾	170–190	2	15–20
Sponge cake (3 to 6 eggs) ²⁾	175–195	2	22–30
Swiss roll ²⁾	160–180	2	15–25
Yeast mixtures and quark dough			
To prove dough	50	5)	15–30
Gugelhupf	150–170	2	50–60
Stollen	150–170	2	55–65
Streusel cake	150–170	2	35–45
Fresh fruit cake (tray)	160–180	2	40–55
White bread	160–180	2	50–60
Whole grain bread ³⁾	170–190	2	50–60
Pizza (tray) ²⁾	170–190	2	35–45
Onion tart	170–190	2	35–45
Apple turnovers (1 [2] tray(s))	150–170	2 [1+ 3]⁴⁾	25–30
Choux pastry²⁾, Eclairs (1 [2] tray(s))	160–180	2 [1+ 3]⁴⁾	30–45
Puff pastry (1 [2] tray(s))	170–190	2 [1+ 3]⁴⁾	20–25
Meringues, Macaroons	120–140	2 [1+ 3]⁴⁾	25–50

The data for the recommended function is printed in bold.





In general, if a range of temperatures/times is given, it is best to select a lower temperature and to check the food after the shortest time.

Baking chart

Conventional heat 			Intensive bake 		
Temperature in °C	Shelf level	Duration ¹⁾ in min.	Temperature in °C	Shelf level	Duration ¹⁾ in min.
170–190 ³⁾	3	10–20	–	–	–
170–190 ³⁾	3	20–40	–	–	–
180–200 ³⁾	2	12–16	–	–	–
50	⁵⁾	15–30	–	–	–
160–180	1	50–60	–	–	–
150–170	2	55–65	–	–	–
170–190	2	35–45	–	–	–
170–190	3	40–55	170–190	2	40–55
160–180	2	50–60	–	–	–
190–210	2	50–60	–	–	–
190–210	2	30–45	170–190	2	40–50
180–200	2	25–35	170–190	2	25–35
160–180	2	25–30	–	–	–
180–200 ³⁾	3	30–40	–	–	–
190–210 ³⁾	2	20–25	–	–	–
120–140 ³⁾	2	25–50	–	–	–

- 1) Unless otherwise stated, the times given are for an oven which has not been pre-heated. With a pre-heated oven shorten times by up to 10 minutes.
- 2) Do not use Rapid heat-up  during the heating-up phase.
- 3) Pre-heat the oven.
- 4) Take baking trays out of the oven early if the food is sufficiently browned before the specified time has elapsed.
- 5) Place the rack on the floor of the oven, and stand the bowl containing the dough on the rack.

Roasting tips

Recommendations	Notes
Function Fan plus 	You can also use Conventional heat  .
Containers Any heat-resistant containers	<p>The Miele Gourmet oven dish, roasting pans with a lid, ovenproof china or glass, roasting bags, the universal tray, the rack on top of the universal tray, the anti-splash insert (if you have one) in the universal tray.</p> <p>We recommend roasting in a covered pot, as</p> <ul style="list-style-type: none"> – this ensures that sufficient stock remains for making gravy. – and the oven stays cleaner, too.
Shelf level 2nd shelf level from the bottom	
Pre-heating Generally not required	Place the covered pot on the rack into a cold oven. Pre-heating is only required when roasting beef/fillet.
Temperature Please refer to the roasting chart.	<ul style="list-style-type: none"> – Do not select a higher temperature than that suggested. The meat will brown on the outside, but will not be properly cooked through. – With Fan plus , a temperature of 20 °C less than for Conventional heat  is sufficient. – For cuts which weigh 3 kg or more, select a temperature approx. 10 °C lower than that given in the roasting chart. Roasting will take longer at the lower temperature, but will be more even. – For roasting directly on the rack, select a temperature that is about 20 °C lower than for roasting in a covered pot.
Roasting times Please refer to the roasting chart.	To calculate the roasting time: The traditional British method is to allow 15 to 20 minutes per lb/450 grammes, according to type of meat, plus approx. 20 minutes, adjusting the length of time as roasting proceeds to obtain the required result.

Useful tips

Browning

Browning only occurs towards the end of the roasting time. Remove the lid about halfway through the roasting time if a more intensive browning result is desired.

Standing time

At the end of the programme, take the roast out of the oven, wrap in aluminium foil and leave to stand for about 10 minutes. This helps retain juices when the meat is carved.



Roasting poultry

For a crisp finish, baste the poultry ten minutes before the end of cooking time with slightly salted water.

Frozen meat

Do not roast deep frozen meat. Meat should be thoroughly defrosted before roasting.

Roasting chart

Food	Recommended shelf level	Fan plus 		Conventional heat  ¹⁾	
		Temperature in °C ²⁾	Time in min. ³⁾	Temperature in °C ²⁾	Time in min. ³⁾
Topside of beef, approx. 1 kg	2	170 – 190	100 – 120	190 – 210	100 – 120
Beef fillet or roast beef, approx. 1 kg ⁴⁾	2	190 – 210	45 – 55	200 – 220	45 – 55
Venison, approx. 1 kg	2	180 – 200	90 – 120	190 – 210	90 – 120
Pork joint, approx. 1 kg	2	170 – 190	100 – 120	200 – 220	100 – 120
Pork joint with crackling, approx. 2 kg	2	150 – 170	160 – 180	180 – 200	120 – 150
Gammon joint, approx. 1 kg	2	170 – 190	60 – 70	200 – 220	60 – 70
Meat loaf, approx. 1 kg	2	160 – 180	70 – 80	190 – 210	70 – 80
Veal, approx. 1.5 kg	2	170 – 190	100 – 120	190 – 210	100 – 120
Leg of lamb, approx. 1.5 kg	2	170 – 190	90 – 120	200 – 220	90 – 120
Rack of lamb, approx. 1.5 kg ⁴⁾	2	170 – 190	50 – 60	190 – 210	50 – 60
Poultry, 0.8 – 1 kg	2	170 – 190	60 – 70	190 – 210	60 – 70
Poultry, approx. 2 kg	2	170 – 190	90 – 110	190 – 210	90 – 110
Poultry, stuffed, approx. 2 kg	2	170 – 190	110 – 130	190 – 210	110 – 130
Poultry, approx. 4 kg	2	160 – 180	150 – 180	180 – 200	150 – 180
Fish, whole, approx. 1.5 kg	2	160 – 180	35 – 55	190 – 210	35 – 55

1) We recommend Fan plus  for roasting, however, Conventional heat  can also be used.

2) Temperature in a covered pot.

If open roasting, set the temperatures 20 °C lower.

3) Unless otherwise stated, the times given are calculated on the basis of an oven which has not been pre-heated.

4) Pre-heat the oven.

In general, if a range of temperatures and times is given, it is best to select a temperature in the middle and to check the food after the shortest time.

This type of cooking is ideal for cooking beef, pork, veal or lamb when a tender result is required.

First sear the meat all over at a high temperature on the hob in order to seal it.

Then cook the meat in the oven at a low temperature over a long period.

The meat juices inside the joint will start to circulate evenly throughout the meat to reach the outer layers.

This gives very tender and succulent results.

For good results when slow cooking at low temperatures over a long period, please note:

- Use lean meat which has been correctly hung and trimmed. The meat should be taken off the bone before cooking.
- For searing use a suitable cooking oil that can withstand high temperatures.
- Do not cover meat during cooking.
- Cooking takes between 2-4 hours depending on the size and amount of meat and on the degree of doneness and browning required.

Proceed as follows:

We recommend using the universal tray with the rack on top.

- Place the universal tray with the rack on top in the oven on shelf level 2.
- Select the Conventional heat  function.
- Pre-heat the oven, rack and universal tray at 130 °C for approx. 15 minutes.

Do not use Rapid heat-up  to pre-heat the oven.

- Whilst the oven is pre-heating, sear the meat thoroughly on the hob.

 **Danger of burning.**
Please be aware that the oven compartment will be very hot when you put the meat in the oven.

- Place the seared meat on the rack.
- Reduce the temperature to 100 °C.

Notes on Slow cooking

It is a good idea to programme the duration.

- Enter the duration, see "Operation – Entering a cooking duration".
- You could use a food probe if you have one. Core temperatures are listed in the chart.
- Continue cooking until the end of the cooking duration.

Useful tips

Because it has been cooked using low temperatures,





- meat can be carved straight from the oven. It does not need to rest.
- meat can be kept warm quite safely in the oven until it is served. This will not affect the result in any way.
- the meat is an ideal temperature to eat straight away. Serve on pre-heated plates with very hot sauce or gravy to prevent it cooling down too quickly.

Cooking duration/Core temperatures

Food	Duration in Min.	Core temp. in °C
Sirloin joint		
– rare	60–90	48
– medium	120–150	57
– well done	180–240	69
Pork fillet	120–150	63
Boned gammon	150–210	68
Boned saddle of veal	180–210	63
Boned saddle of lamb	90–120	60

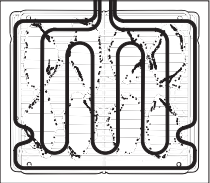
 Grill with the oven door closed.

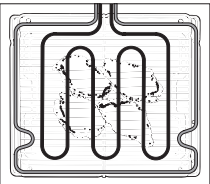
If you grill with the door open, hot air will escape from the oven instead of being cooled by the cooling fan. The controls will get hot. Danger of burning.

Function	Notes
Full grill  	For grilling thin cuts in large quantities and for browning large baked dishes. The whole grill element will get hot and glow red.
Economy grill  : 	For grilling thin cuts in small quantities and for browning small baked dishes. The inner part of the grill heating element will get hot and glow red.
Fan grill  :	For grilling thicker items, e.g. rolled meat, poultry pieces.

Grilling tips

Recommendations	Notes
<p>Containers</p> <p>Rack on the universal tray Anti-splash insert in the universal tray (if you have one)</p>	<p>Do not use the baking tray.</p>
<p>Shelf level from the bottom</p> <p>Please refer to the grilling chart.</p>	<p>For thin cuts use shelf level 4 or 5 For thicker cuts use shelf level 3 or 4</p>
<p>Pre-heating</p> <p>is necessary</p>	<p>Pre-heat the grill for approx. 5 minutes with the door shut.</p>
<p>Temperature</p> <p>Please refer to the grilling chart.</p>	<ul style="list-style-type: none"> – For thin cuts of meat (e. g. chops or steak):  – For grilling thicker items, (e. g. rolled meat, poultry) 240 °C – Do not select a higher temperature than that suggested. The meat will brown on the outside, but will not be properly cooked through.
<p>Grilling time</p> <p>Please refer to the grilling chart.</p>	<ul style="list-style-type: none"> – Flat pieces of fish and meat usually take 6 – 8 minutes per side. Thicker pieces take a little longer. – With rolled meat, allow approx. 10 minutes per cm diameter. – Turn food half way through cooking.

Preparing food for grilling

Rinse briefly under running cold water, pat dry and season with pepper and herbs. Do not season meat with salt before grilling as this draws the juices out.

Add a little oil to lean meat if necessary. Do not use other types of fat as they can burn and cause smoke.

Clean fish in the normal way. To enhance the flavour, add a little salt or squeeze a little lemon juice over the fish.

Grilling

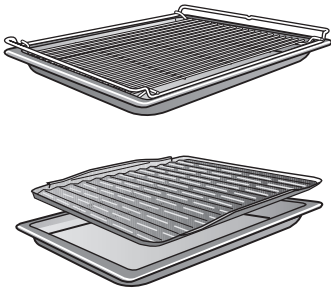

- Assemble the rack or anti-splash insert (if you have one) on the universal tray as illustrated.
- Place the food on the rack.
- Select the required function and set the temperature.
- Pre-heat the grill for approx. 5 minutes with the door shut.
- Place the food under the grill and shut the door.
- Turn food half way through cooking.

Useful tips

It is best to grill food of a similar thickness at the same time so that the grilling time for each item does not vary too greatly.















To grill thicker pieces of food more gradually after an initial high temperature, continue grilling at a lower temperature setting or use a lower shelf runner to allow the food to cook through to the centre.

One way of finding out how far through a piece of meat has been cooked is to press down on it with a spoon.

- If there is very little resistance to the pressure of the spoon, it will still be red on the inside ("rare").
- If there is some resistance the inside will be pink ("medium").
- If there is great resistance, it is thoroughly cooked through ("well done").

Grilling chart

Pre-heat the grill for approx. 5 minutes with the door shut.

Food to be grilled	Recommended shelf level	Full grill  / Economy grill 		Fan grill 	
		Temperature in °C	Total grilling time in min. ¹⁾	Temperature in °C	Total grilling time in min. ¹⁾
Thin cuts					
Steak	4		10 – 16	220	20 – 25
Kebabs	4	240	25 – 30	220	16 – 20
Chicken kebabs	4	240	20 – 25	200	23 – 27
Escalope	4 or 5 ²⁾		12 – 18	220	23 – 27
Liver	4 or 5 ²⁾		8 – 12	220	12 – 15
Burgers	4 or 5 ²⁾		14 – 20	220	18 – 22
Sausages	4 or 5 ²⁾		10 – 15	220	9 – 13
Fish fillet	4 or 5 ²⁾		12 – 16	220	13 – 18
Trout	4 or 5 ²⁾		16 – 20	220	20 – 25
Toast	4 or 5 ²⁾		2 – 4	220	3 – 6
Cheese toast	4 or 5 ²⁾		7 – 9	220	5 – 8
Tomatoes	4		6 – 8	220	8 – 10
Peaches	4		6 – 8	220	15 – 20
Thicker cuts					
Chicken (approx. 1 kg)	3	240	50 – 60	190	60 – 65
Rolled meat, Ø 7 cm, (approx. 1 kg)	2	240	75 – 85	200	100 – 110
Pork shank (approx. 1 kg)	2	240	100 – 120	200	95 – 100
Sirloin, approx. 1 kg	2	–	–	250	25 – 35

1) Turn half way through the grilling time.

2) Select the appropriate shelf level for the thickness of the food.

The Defrost  function uses the fan to circulate air at room temperature.

Please note:

- Where possible remove the packaging and put the food to be defrosted on the universal tray or into a suitable dish.
- When defrosting poultry, put it on the rack over the universal tray to catch the defrosted liquid so that the meat is not lying in this liquid.

 It is particularly important to observe food hygiene rules when defrosting poultry. Do not use the liquid from the defrosted poultry. Pour it away, and wash the tray, the sink and your hands. Danger of salmonella poisoning.

- Fish does not need to be fully defrosted before cooking. Defrost so that the surface is sufficiently soft to take herbs and seasoning.

 Do not refreeze food once it has thawed.

Defrosting times

The time needed for defrosting depends on the type and weight of the food, and at what temperature it was deep frozen. The following chart is for guidance only. It is important to check that food is thoroughly defrosted.

Chicken, 800 g	90 – 120 min.
Meat, 500 g	60 – 90 min.
Meat, 1000 g	90 – 120 min.
Sausages, 500 g	30 – 50 min.
Fish, 1000 g	60 – 90 min.
Strawberries, 300 g	30 – 40 min.
Sponge cake, 500 g	20 – 30 min.
Bread, 500 g	30 – 50 min.

Cooking ready meals

We recommend using Fan plus .

- Select the required function and set the temperature.
- When the temperature indicator light  goes out, place the dish in the pre-heated oven.

Cook frozen cakes and pizza on baking paper on the rack rather than on the baking tray or the universal tray. Cooking large frozen items on the baking tray or the universal tray can cause the metal to distort. This distortion will increase with each subsequent use.

Frozen food such as oven chips or croquette potatoes can, however, be cooked on the baking tray or the universal tray.

Examples of ready meals

Food	Temperature in °C *	Shelf level from the bottom*	Time in min.*	Notes
Potato, pasta or vegetable bake	250	2	20 – 25	Place in a suitable dish
Lasagne, cannelloni	190	2	35 – 40	Remove the lid
Filled baguette, panini	200	2	12 – 15	Place on baking paper, directly on the rack
Pre-cooked pizza	200	2	12 – 20	Place on baking paper, directly on the rack
Pre-cooked mini pizza	220	2	8 – 10	Place on baking paper, directly on the rack
Potato pancakes, Rösti, croquettes	220	2	12 – 20	Place on baking paper, directly on the rack

* Observe recommended temperatures, cooking times and position in the oven given on the manufacturer's packaging.

Miele branded cleaning and conditioning products are available from the Miele Spare Parts Department or via the internet on www.miele-shop.com.

 Do not use a steam cleaner to clean the appliance. The steam could reach electrical components and cause a short circuit.

Appliance front

Remove any soiling immediately. If this is not done, it might become impossible to remove and could cause the surface to alter or discolour.

Clean the front using a damp Miele microfibre E-cloth or with a clean sponge and a solution of hot water and washing-up liquid. Wipe dry using a soft cloth.

The external surfaces of this appliance are all susceptible to scratching. Scratches on glass surfaces could even cause a breakage in certain circumstances. Contact with unsuitable cleaning agents can alter or discolour the external surfaces.

To prevent damage to your appliance when cleaning, do not use:

- cleaning agents containing soda, ammonia, acids or chlorides,
- cleaning agents containing descaling agents,
- abrasive cleaning agents, e.g. powder cleaners and cream cleaners,
- solvent-based cleaning agents,
- stainless steel cleaning agents,
- dishwasher cleaner,
- oven sprays,
- glass cleaning agents,
- hard, abrasive sponges and brushes, e.g. pot scourers,
- melamine eraser blocks,
- sharp metal scrapers.

Cleaning and care

Accessories

Universal tray, baking tray , anti-splash insert

(depending on model)

The surface has been treated with **PerfectClean enamel**.

Please refer to the section on "PerfectClean" for information on cleaning and care.

Rack, runners

Use hot water and a little washing-up liquid, or a non-abrasive stainless steel cleaning agent, to clean the chrome surfaces.

Oven interior

Allow the oven to cool down before cleaning.
Danger of burning

The oven interior should be cleaned after each use. If this is not done subsequent soiling from baking and roasting will become worse and make cleaning harder. In extreme cases soiling will be impossible to remove or even cause damage to the surface material.

The surface of the oven interior has been treated with **PerfectClean enamel**.

When baking items with a high salt content (e.g. continental pretzels) place them on baking parchment in the universal tray. Sodium deposits can

cause lasting discolouration to PerfectClean surfaces.

Please refer to the section on "PerfectClean" for information on cleaning and care.

The removable **back panel, side panels and roof liner** are coated with a dark grey **catalytic enamel**.

See the cleaning instructions for "Catalytic enamelled surfaces".

To make cleaning easier

- remove the oven door,
- dismantle the door,
- take out any FlexiClip runners,
- take out the runners,
- remove the catalytic enamelled back panel, side panels and roof liner.
- lower the top heating/grill element.

Instructions for doing so are given further on in this section.

Seal and inside of the oven door

Grease desposits on the seal between the inside of the oven door and the oven interior can cause it to become brittle and cracked.

It is best to clean the seal and the inside of the door after each with a Miele E-cloth or a clean sponge and a solution of hot water with a little washing-up liquid. Wipe dry using a soft cloth.

PerfectClean

Before using for the first time remove any stickers from PerfectClean surfaces.

The **enamelled surfaces** of the oven interior, the baking tray (if applicable), universal tray and anti-splash insert (if applicable) have been treated with a special type of enamelling called "**PerfectClean**".

This surface has very good anti-stick properties and is much easier to keep clean than conventional oven enamel, if cleaned regularly.

Food can be taken off it more easily, and soiling from baking and roasting is easier to remove.

The following notes on cleaning and care should ensure that the anti-stick and easy clean properties of PerfectClean last for many years.

PerfectClean surfaces can be treated as you would treat glass.

Food can be sliced or cut up on the PerfectClean surface in the same way as on a baking tray with conventional enamel.

Allow the oven and any accessories to cool down before cleaning.
Danger of burning.

Normal soiling

Clean as soon as possible after each use with a dishcloth, soft sponge or a soft nylon brush, and a solution of hot water and a little washing-up liquid. The longer soiling is left, the harder it may become to remove.

Stubborn soiling

Stubborn soiling, e.g. from roasting, may need to be soaked first with a damp sponge to loosen it and if necessary a non-abrasive stainless steel spiral pad or a scraper suitable for glass can be used to remove it.

After cleaning, rinse thoroughly with clean water. The water must run off the surface easily. Any residual cleaning agents will hinder this effect.

Using oven sprays on very stubborn soiling

Some oven cleaners contain strong alkalines and / or abrasive materials. Because PerfectClean enamel is designed to be easily cleaned, the use of these cleaners is not recommended. However, if you still cannot get the surface clean, an oven cleaner can be used, but for a few minutes only.

Cleaning and care

Do not attempt to use on a hot oven or accessories. Allow the PerfectClean surfaces to cool down to room temperature before applying an oven spray.

Remove the catalytic back panel, side liners (if fitted) and roof liner before using oven spray. The chemicals used in oven sprays will damage catalytic enamel, rendering it ineffective.

Apply spray oven cleaner to the soiled areas, then leave to take effect **for a few minutes only** (no more than 10 minutes).

If necessary use a soft sponge, soft nylon brush or a scraper suitable for glass surfaces to loosen the soiling.

Repeat the process if necessary.

After cleaning, rinse thoroughly with clean water and then dry thoroughly.

For optimum performance of PerfectClean enamel it is important to clean the oven and accessories after each use.

The surfaces will become harder to clean and the anti-stick properties will deteriorate if soiling is not removed after each use and allowed to build up. In extreme cases cleaning may become impossible.

The following cause lasting damage to the surface structure and reduce the anti-stick effect and must not be used on PerfectClean surfaces:

- abrasive cleaning agents, e.g. powder cleaners and cream cleaners,
- cleaning agents for ceramic hobs,
- wire wool or metal scourers,
- abrasive sponges, e.g. pot scourers or sponges which have been previously used with abrasive cleaning agents,
- oven spray must not be used in a hot oven or left on for too long,
- PerfectClean enamelled items must not be washed in a dishwasher.
- do not spot-clean by rubbing the surface.

Note:

- Soiling such as spilt juices and cake mixtures are best removed whilst the oven or tray is still warm. Exercise caution, make sure the oven is not too hot - danger of burning.
- Spilt fruit juices may cause lasting discolouration to the surfaces and roasting can cause matt areas to appear. Clean these following the instructions given above and do not use force to remove them. This discolouration is permanent but will not affect the efficiency of the enamel.

Catalytic enamel surfaces

The back panel, roof liner and side panels (if fitted) are coated with dark grey catalytic enamel.

Soiling from oil and fat is burnt off these surfaces when very high temperatures are used in the oven. The higher the temperature, the more effective the process.

The catalytic coating becomes ineffective through using

- abrasive cleaning agents,
- hard brushes or abrasive sponges,
- oven sprays.

Remove the catalytic back panel, side panels and roof liner from the oven before cleaning the PerfectClean oven surfaces with oven spray.

Note that deposits of **spices, syrups and similar substances** are not removed from the catalytic coating by this process. These should be removed by hand whilst still fresh, using a mild solution of hot water and washing-up liquid applied with a soft sponge or brush. Remove the panels from the oven to do this.

Soiling caused by **oil and grease splashes** are removed from catalytic coated surfaces when the oven is heated to a high temperature. To do this:

- Take all accessories out of the oven.
- Wipe large deposits of soiling from the oven interior and the inside of the door before starting the cleaning process to avoid them baking onto

PerfectClean surfaces and becoming impossible to remove.

- Select Fan plus .
- Set the highest temperature setting.

Run the oven for approx. 1 hour. The length of time will depend on the level of soiling.

The timer can also be used to set the finish time. See "Entering a cooking duration".

If the catalytic coated panels are very heavily soiled with oil and grease, a film will develop on the oven surface during the cleaning process which can be wiped off with warm water and a little washing-up liquid once cool.

- Finally, clean the PerfectClean surfaces and the inside of the door.

Any remaining soiling will gradually disappear with each subsequent use of the oven at high temperatures.

Should the catalytic coating on the back panel, roof liner or side panels become ineffective through improper use or heavy soiling, a replacement can be obtained from your Miele dealer or the Miele Spare Parts Department.

Cleaning and care

To remove the oven door

The oven door is connected to the oven by hinges.

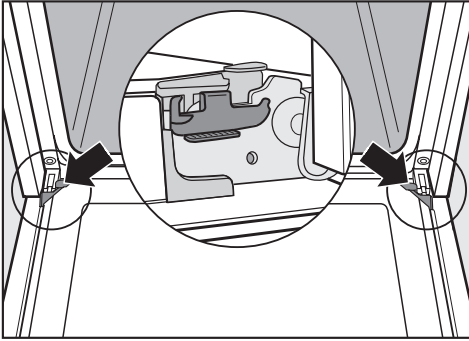

Before removing the door, the locking clamps on both hinges have to be released.

- Open the door fully.

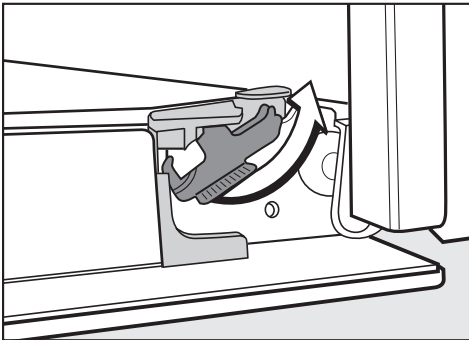

- To release the locking clamps on the hinges turn them upwards as far as they will go until they are at an angle. See illustration.

- Then lift the door upwards as far as it will go.

Do not attempt to take the door off the hinge guides when it is in a horizontal position. The guides will close, and damage the appliance. Danger of injury.



- Hold the door securely at both sides and lift upwards off the hinge guides.

Do not lift the door off by the handle. The handle could break and damage the door.

Make sure that you lift the door off equally on both sides.

To dismantle the oven door

The oven door is made up of two panes of glass and has vents at the top and bottom.

When the oven is operating, air is circulated through the door to keep the outer pane cool.

If condensate has worked its way in between the glass panes, the door can be dismantled in order to clean in between the panes.

When cleaning the glass panes please follow the same instructions given for cleaning the appliance front.

Do not use abrasive cleaning agents, sponges or brushes, as these can scratch the surface. These could damage the surface. Scratches can also cause the glass to break.

Do not use an oven spray. This will damage the surface of the aluminium surrounds.

To avoid the risk of breakage, it is advisable to place the panes on a table protected by a soft cloth (e.g. a towel).

Always remove the oven door before dismantling it.

- Place the door on a protective surface (e.g. on a table cloth) to prevent it getting scratched. The door handle should just overhang the edge of the table so that the glass lies flat to prevent it from getting broken during cleaning.

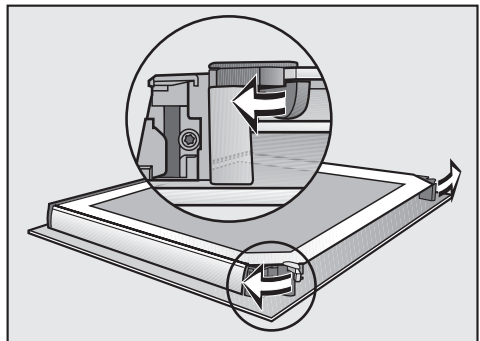

- Flip the glass pane retainers outwards to open them.

You can now remove the inner pane.

Cleaning and care

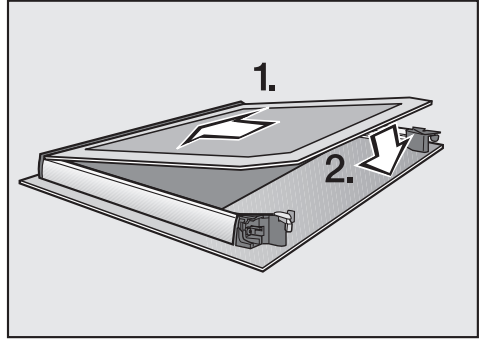
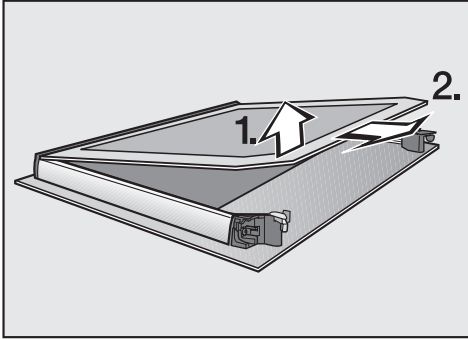

- **Gently** lift the inner pane up and out of the plastic strip.
- Clean the glass panes and other parts with a Miele E-cloth or a clean sponge and a solution of hot water with a little washing-up liquid. Wipe dry using a soft cloth.
- To refit the door:

- Push the inner pane into the plastic strip and place it between the retainers. "Miele" must be visible at the top.

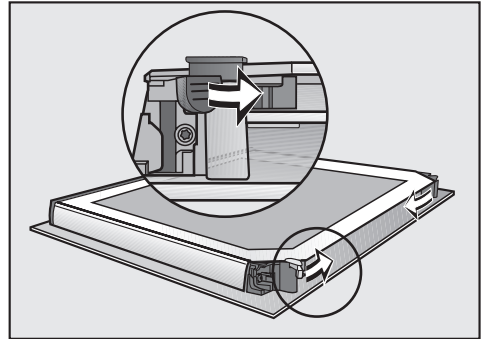

- Flip the glass pane retainers inwards to close them.

To refit the door

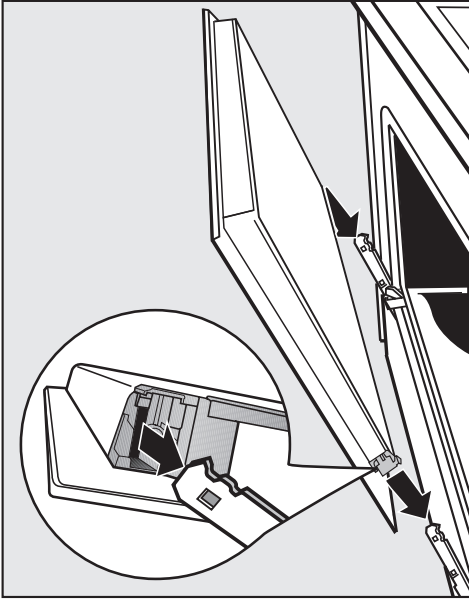

- Hold the door securely at both sides and carefully fit it back onto the hinge guides.

Make sure that the door goes back on straight.

- Open the door fully.

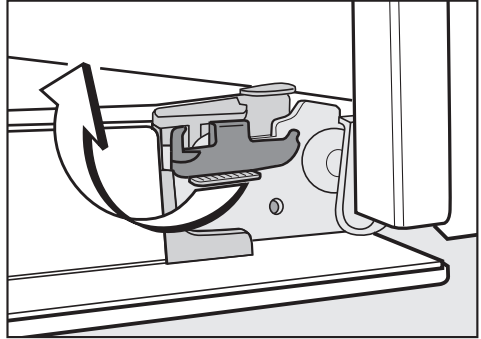

- Flip both locking clamps back up as far as they will go into a horizontal position.

It is essential that the locking clamps are flipped down when the door is refitted after cleaning. Otherwise the hinges could work loose, resulting in damage to the door.

Cleaning and care

To remove the runners

 Make sure the oven heating elements are switched off and cool. Danger of burning.

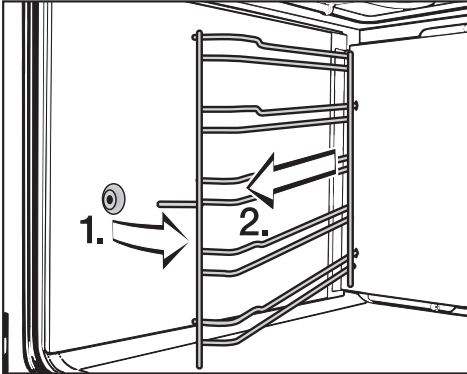

- Pull the runners forwards out of the holder and remove, together with the catalytic side panels (if fitted).

Reassemble in the reverse order, carefully ensuring all parts are correctly in place.

To remove the catalytic enamelled back panel, side panels and roof liner

 Make sure the oven heating elements are switched off and cool. Danger of burning.

See "Cleaning and care" for information on cleaning.

Back panel

- Remove the runners, together with the catalytic side panels (if fitted).
- Loosen the screws in the back panel and take it out.

The oven must not be used without the back panel fitted. This could cause considerable injury.

Reassemble in the reverse order, carefully ensuring all parts are correctly in place.

Roof liner (if fitted)

- Remove the runners, together with the catalytic side panels (if fitted).

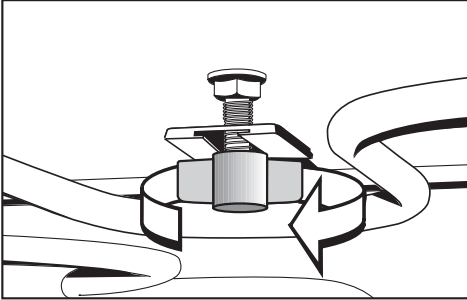

- Unscrew the wing nut.
- Gently lower the element.

Do not use force to pull it down as this can cause the element to break.

- Take out the roof liner.

Reassemble in the reverse order, carefully ensuring all parts are correctly in place.

Make sure that the wing nut is screwed back on properly.

Side panels (if fitted)

- Remove the runners, together with the catalytic side panels.
- Remove the side panels from the runners.

Reassemble in the reverse order, carefully ensuring all parts are correctly in place.



Problem solving guide

With the aid of the following guide, minor problems can be easily corrected without contacting Miele.

 Do not attempt to open the appliance casing yourself! Installation, maintenance and repairs may only be carried out by a suitably qualified and competent person in strict accordance with current national and local safety regulations. Repairs and other work by unqualified persons could be dangerous. The manufacturer cannot be held liable for unauthorised work.

Problem	Possible cause and remedy
The display is dark.	■ Check whether the mains fuse has tripped. If it has not tripped, contact a qualified electrician or Miele.
The oven does not heat up.	■ Check that the function selector and the temperature selector have been set at the function and temperature required. ■ Check whether the mains fuse has tripped. If it has not tripped, contact a qualified electrician or Miele.
On ovens with a clock/timer, "0:00" starts flashing in the display.	There has been a power cut. ■ Enter the time of day again. ■ Enter the cooking programme again.
A noise can be heard after a cooking programme.	This is not a fault. The cooling fan continues to operate after a programme has finished. It switches itself off once the oven has dropped to a certain temperature.

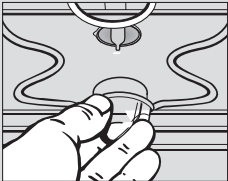
Problem solving guide

Problem	Possible cause and remedy
<p>The interior lamp is not working.</p> 	<ul style="list-style-type: none"> ■ Disconnect the appliance from the electricity supply: Switch off and unplug at the socket, or disconnect the fuse, or switch off at the isolator as appropriate. ■ Turn the lamp cover a quarter turn anti-clockwise to release it and then pull it downwards to take it out. ■ Replace it with a new halogen lamp (Osram 66725 AM/A, 230 V, 25 W, G9). ■ Refit the lamp cover and turn it clockwise to secure it. ■ Reconnect the appliance to the mains electricity supply.
<p>Cakes and biscuits are not cooked properly after following the times given in the chart.</p>	<ul style="list-style-type: none"> ■ Check that the correct temperature has been set. ■ Check whether there has been a change to the recipe. The addition of more liquid or more eggs makes a moister mix which would need longer to cook.
<p>Cakes/biscuits are browning unevenly.</p>	<p>There will always be a slight unevenness.</p> <ul style="list-style-type: none"> ■ If the unevenness is pronounced, check that the right temperature and shelf level have been selected. <p>With Conventional heat , the material and colour of the bakeware is also important: light coloured, shiny tins are less suitable.</p>
<p>There are spots like rust on the catalytic surfaces.</p>	<p>When roasting on the rack, the circulating air sometimes picks up spices, which are then deposited on the oven interior walls. These residues are not removed by catalytic cleaning, and should be removed while fresh with a mild solution of hot water and washing-up liquid applied with a soft brush.</p>

After Sales / Guarantee

After sales service

In the event of a fault which you cannot correct yourself, or if the appliance is under guarantee, please contact

– your Miele Dealer

or

– Miele (see back cover for contact details).

A call-out charge will be applied for service visits where the problem could have been resolved as described in these instructions.

When contacting your Dealer or Miele, please quote the model and serial number of your appliance.

This information is given on the data plate, visible on the front frame of the oven, with the door fully open.

Please note that telephone calls may be monitored and recorded for training purposes.

Guarantee

For information on the appliance guarantee specific to your country please contact Miele. See back cover for contact details.

In the UK, your appliance is guaranteed for 2 years from the date of purchase. However, you must activate your cover by calling 0845 365 6640 or registering online at www.miele.co.uk.

Optional accessories

A range of additional accessories as well as cleaning and care products are available for your Miele oven. Depending on product they are available to order from your Miele Dealer, the Miele Spare Parts Department or via the internet on www.miele-shop.com.

FlexiClip telescopic runners

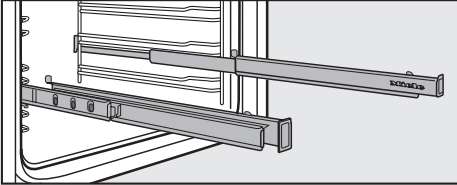

Up to 5 pairs of FlexiClip telescopic runners can be fitted in the oven.

FlexiClip telescopic runners enable a shelf to be drawn out to give a good view of cooking in progress.

Baking tray, universal tray and rack

These items, supplied with your oven, are also available to order.

When ordering, please quote the model number of your appliance.

Pizza stone

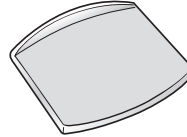

The pizza stone is ideal for items which need a well baked base such as pizza, quiche, bread, bread rolls and savoury snacks.

The pizza stone is made from heat retaining fire brick and is glazed.

Place it directly on the rack.

A paddle made of untreated wood is supplied with it for placing food on the pizza stone and taking it off.

Flan/Pizza dish

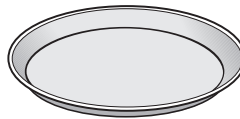

This circular pan is suitable for cooking pizzas, flat cakes made with yeast or whisked mixtures, sweet and savoury tarts, baked desserts, and can also be used for frozen cakes and pizzas.

The surface has been treated with PerfectClean enamel.

Optional accessories

Gourmet oven dish

The gourmet oven dish can be placed in the oven directly on the runners. It has non-tip safety notches like the universal tray to prevent it being pulled out too far.

It has an anti-stick coating.

It is available in two sizes:

- HUB 5000-M (internal dimensions: approx. 38 x 22 x 8 cm)



- HUB 5000-XL (internal dimensions: approx. 38 x 35 x 8 cm)

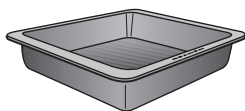

Gourmet oven dish lid

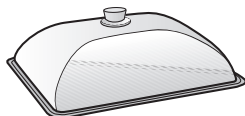
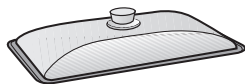

When ordering a lid, please specify the gourmet oven dish it is to be used with (HUB 5000 M or XL).

Catalytic liners

Replacement side and roof liners are available to order if required. Please quote the model number of your oven when placing your order.

Miele E-cloth

Removes grease and stains and leaves no smearing. Suitable for cleaning surfaces such as stainless steel, glass, plastic and chrome without the use of chemicals.

Miele oven cleaner

Suitable for removing stubborn soiling. It is not necessary to pre-heat the oven beforehand.

All electrical work should be undertaken by a suitably qualified and competent person in strict accordance with current national and local safety regulations (BS 7671 in the UK).

Installation, repairs and other work by unqualified persons could be dangerous. The manufacturer cannot be held liable for unauthorised work.

Ensure power is not supplied to the appliance until after installation or repair work has been carried out.

The **voltage and connected load** are given on the data plate, visible below the oven interior, with the door open. Ensure that these match the household mains supply. Please quote these data, and the model and serial number when contacting Miele.

Connection of this appliance should be made via a fused connection unit or a suitable isolator, which complies with national and local safety regulations, and the on/off switch should be easily accessible after the appliance has been built in.

If the switch is not accessible after installation (depending on country) an additional means of disconnection must be provided for all poles.

For extra safety it is advisable to protect the appliance with a residual current device (RCD). Please contact a qualified electrician for advice.

When switched off there must be an all-pole contact gap of 3 mm in the

isolator switch (including switch, fuses and relays acc. to EN 60 335).

Important U.K.

The appliance is supplied for connection to a 230-240 V, 50 Hz supply with a 3-core cable.

The wires in the mains lead are coloured in accordance with the following code:

Green/yellow = earth

Blue = neutral

Brown = live

WARNING THIS APPLIANCE MUST BE EARTHED

When replacing the cable supplied with another cable or changing the connection, only cable type H 05 VV-F or H 05 RR-F with a suitable cross-sectional area (CSA) may be used (available from the Miele Customer Contact Centre).

Building-in diagrams

Dimensions are given in "mm".

Appliance and niche dimensions

Installation in a base unit

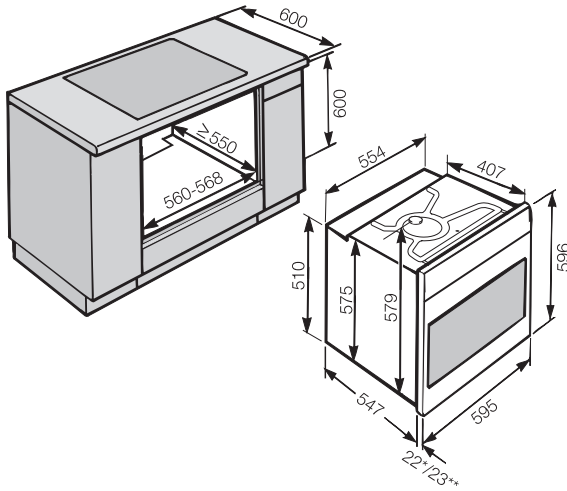

Installation in a tall unit

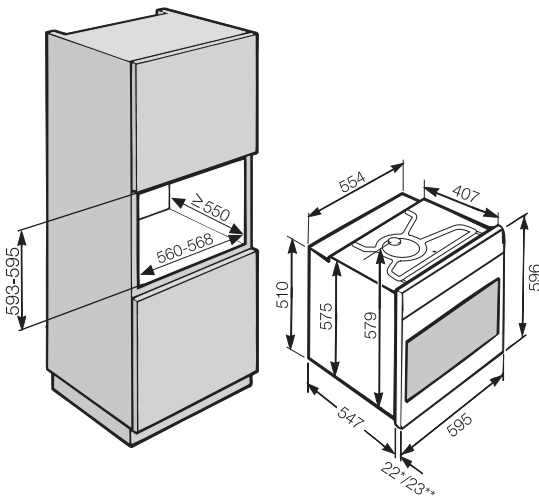

* Appliances with glass front

** Appliances with metal front

Front dimensions

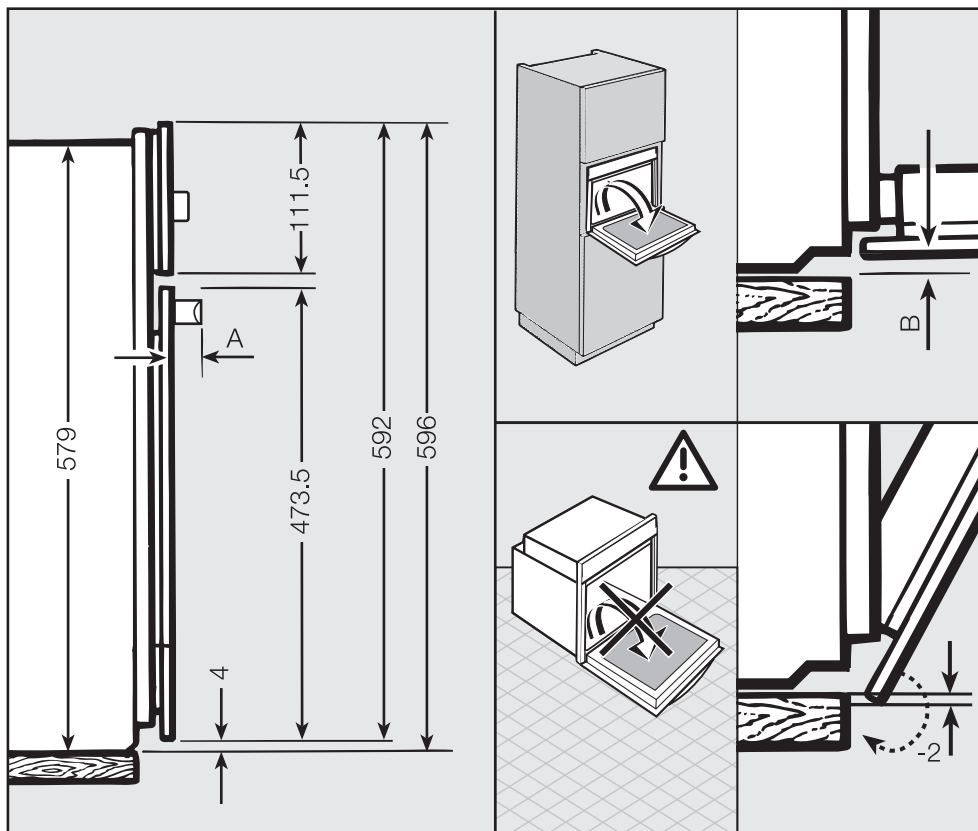

A H 4710: 53.2
H 4810: 47.5

B Appliances with glass front: 2.2
Appliances with metal front: 1.2

Installing the oven

 The appliance must not be operated until it has been correctly installed in its housing unit. Otherwise it poses an electric shock hazard.

Important. Do not fit insulation material inside the housing unit. This would hinder the intake of air to the appliance.

When installing the appliance do not lift it up by the door handle as this can damage the door.

Turn off the mains electricity supply to the isolator.

- Connect the mains cable from the oven to the isolator.
- Push the appliance into the oven housing unit and align it.

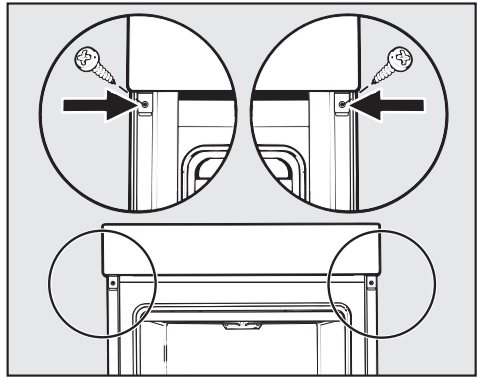

- Open the oven door and using two screws secure it to the side walls of the housing unit through the holes in the oven trim.

United Kingdom

Miele Co. Ltd.
Fairacres, Marcham Road
Abingdon, Oxon, OX14 1TW
Tel: 0845 365 0555, Fax: 0845 365 0777
Customer Contact Centre Tel: 0845 365 6600
E-mail: info@miele.co.uk
Internet: www.miele.co.uk

Australia

Miele Australia Pty. Ltd.
ABN 96 005 635 398
1 Gilbert Park Drive, Knoxfield, VIC 3180
Tel: 1300 464 353, Fax: (03) 9764 7149
Internet: www.miele.com.au

China

Miele (Shanghai) Trading Ltd.
1-3 Floor, No. 82 Shi Men Yi Road
Jing' an District
200040 Shanghai, PRC
Tel: +86 21 6157 3500, Fax: +86 21 6157 3511
E-mail: mieleshanghai@cn.miele.com
Internet: www.miele.cn

Miele (Hong Kong) Limited

41/F - 4101, Manhattan Place
23 Wang Tai Road
Kowloon Bay
Hong Kong
Tel: (852) 2610 1331, Fax: (852) 2610 1013
Email: mielehk@miele.com.hk

India

Miele India Pvt. Ltd.
Ground Floor, Copia Corporate Suites
Plot No. 9, Jasola
New Delhi - 110025
Tel: 011-46 900 000, Fax: 011-46 900 001
E-mail: customercare@miele.in, Internet: www.miele.in

Ireland

Miele Ireland Ltd.
2024 Bianconi Avenue
Citywest Business Campus, Dublin 24
Tel: (01) 461 07 10, Fax: (01) 461 07 97
E-Mail: info@miele.ie, Internet: www.miele.ie

Manufacturer: Miele & Cie. KG

Carl-Miele-Straße 29, 33332 Gütersloh, Germany

Miele

Malaysia

Miele Sdn Bhd
Suite 12-2, Level 12
Menara SapuraKencana Petroleum
Solaris Dutamas No. 1, Jalan Dutamas 1
50480 Kuala Lumpur, Malaysia
Phone: +603-6209-0288
Fax: +603-6205-3768

New Zealand

Miele New Zealand Limited
Unit L, 10-20 Sylvia Park Road
Mt. Wellington, 1060, Auckland, NZ
Tel: 0800 264 353, Fax: 0800 463 453
Internet: www.miele.co.nz

Singapore

Miele Southeast Asia
Miele Pte. Ltd.
163 Penang Road
04 - 02/03 Winsland House II
Singapore 238463
Tel: +65 6735 1191, Fax: +65 6735 1161
E-Mail: infosea@miele.com.sg
Internet: www.miele.sg

South Africa

Miele (Pty) Ltd
63 Peter Place, Bryanston 2194
P.O. Box 69434, Bryanston 2021
Tel: (011) 875 9000, Fax: (011) 875 9035
E-mail: info@miele.co.za
Internet: www.miele.co.za

United Arab Emirates

Miele Appliances Ltd.
P.O. Box 11 47 82
Gold & Diamond Park
Sheikh Zayed Road
Building 6 / Offices Nos. 6-214 to 6-220
Dubai
Tel: +971-4-341 84 44
Fax: +971-4-341 88 52
E-Mail: info@miele.ae, Internet: www.miele.ae